

2PC SCREWED BALL VALVE FEATURES

- 1 Full port
- 2 W. P.: 1000WOG(PN63)
- 3 W. T.: -20°C ~200°C (-4°F ~392°F)
- 4 Investment casting
- 5 Blow-out proof stem
- 6 Anti-static device (option)
- 7 Locking device(option)
- 8 Tapped & drilled mounting pad (option)
- 9 Length conform to DIN 3202/4-M3-2006M3(option)
- 10 Thread type: ASME B1.20.1 (NPT), DIN 2999 & BS21, ISO228/1 & ISO7/1
- 11 **Economical type on optional**

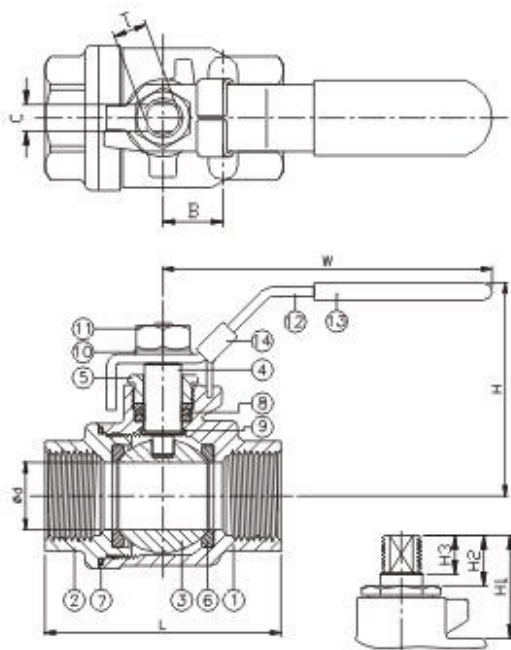

ITEM	PARTS	MATERIAL	
1	BODY	ASTM A351- CF8(M)	ASTM A216- WCB
2	CAP		
3	BALL	ASTM A351-CF8(M)	
4	STEM	ASTM A276-304/316	
5	GLAND NUT	AISI 304	
6	SEAT	PTFE/RTFE	
7	SEAL	PTFE	
8	PACKING	PTFE/RTFE	
9	THRUST WASHER	PTFE	
10	SPRING WASHER	AISI 304	
11	NUT		
12	HANDLE		
13	HANDLE SLEEVE	PVC	
14	LOCKING DEVICE	AISI 304	

DN	d	L	H	W	B	C	H1	H2	H3	T	Torque (N-m)
8	11.6	53	50	102	14	5	32.5	12.5	10.5	5/16"W	4.07
10	13	54	50	102	14	5	32.5	12.5	10.5	5/16"W	4.07
15	15	56	50	102	14	5	32.5	12.5	10.5	5/16"W	4.41
20	20	67	62	120	22	6.5	40.5	16	13.5	3/8"W	5.88
25	25	80	75.5	159	22	8	50	18	15.5	7/16"W	7.35
32	32	94	81	159	24	8	49	17	15.5	7/16"W	8.82
40	38	101	98	188	24	9	60	19	17.5	1/2"W	13.2
50	50	115	108	188	24	9	62	20	17.5	1/2"W	16.2
65	65	155	136	245	35	12	79	31	30.5	3/4"W	44.1
80	80	180	147	245	35	12	78.5	31	30.5	3/4"W	46.6
100	100	225	183	320	50	16	99	53	42	1"W	-

Unit :mm