

CHECKED BY _____
 PRINTED BY _____
 OLD DRAWING NO. _____
 ASGD DRAWING NO. _____
 SIGNATURE _____
 DATE _____

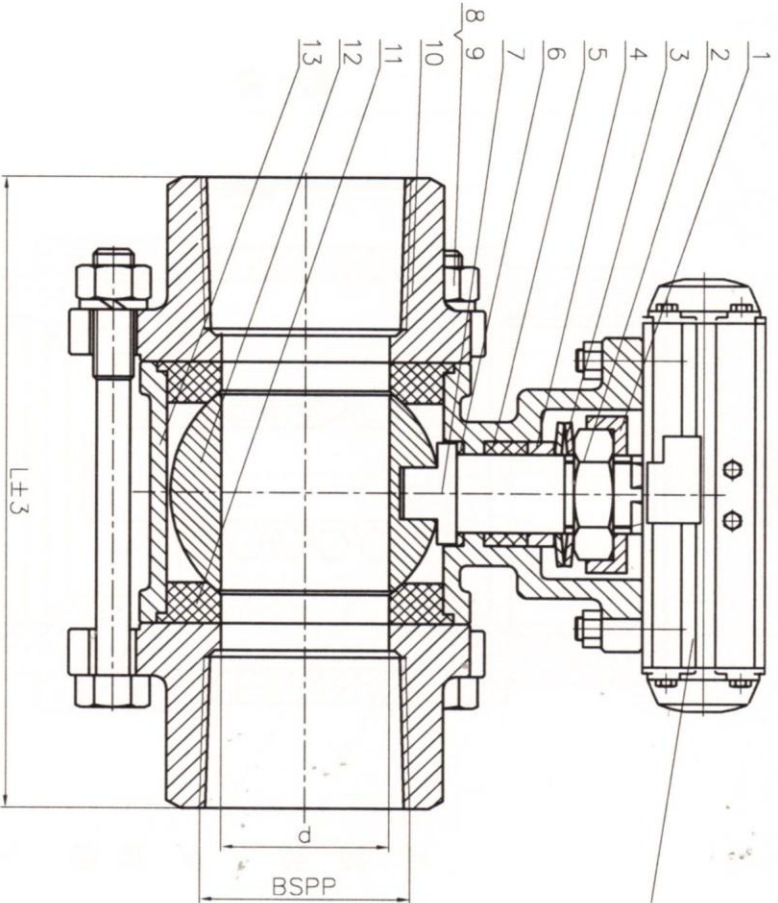

14

Technical Specifications
 1. Design and manufacture refer to ASTM B86 34
 2. Face to face to NGS Standard
 3. End Connection to ISO 228 1
 4. Inpadi on and test to API 598

Performance Specifications	
Normal Pressure	1000PSI
Seal test	1.8 MPa
Gas test	0.6 MPa
Working Temperature	-29~150 °C
Medium	Water oil & gas

NO	PART NAME	QTY	UNIT	ASSEMBLY
7	Stem	304		Assembly
6	Thrust Washer	PIRE		08
5	Packing	PIRE		304
4	Gland	ZI		PIRE
3	Ball and Seat Spring	ZI		08
2	Ball	ZI		ZI
1	Ball Seat	ZI		ZI
NO	PART NAME	UNIT		ASSEMBLY

MARK	QTY	FILE NO.	SIGN	DATE
DESIGN				
CHECK				
TECHNOLOGY				

1000PSI		QTY-1000PSI-01	
NRS 1/2-4		DRAW MARK	
BALL VALVE		WT.	
ASSEMBLY DRAWING		DRAW REV. 00	

1	25	85	1
1/2	15	85	1/2
NRS	D	L	BS